



# KX-TDA30AL

## HYBRID IP-PBX SYSTEM

the voice of business

**Panasonic**  
ideas for life

# PANASONIC COMMUNICATION SOLUTIONS

Panasonic Corporation is a worldwide leader in the development and manufacture of products for a wide range of consumer, business and industrial needs.

Panasonic Corporation was founded in 1918. Today it is one of the largest electronic product manufacturers in the world, comprised of over 556 companies with annual sales of approximately USD\$77 Billion\* and more than 300,000 employees.

Panasonic has been manufacturing telephone systems since 1986 with the launch of the world's first two hybrid port systems (KX-T308 and KX-T616). The cost savings and superior flexibility of these hybrids quickly made them the world's best-selling systems.

In Australia, we have built the business to be one of the flagship

product areas within Panasonic Business Systems. Panasonic Australia has a strong national network of over 80 dealers, covering all States and Territories, both in metropolitan and regional areas.

Panasonic maintains an on-going programme of training and accreditation to ensure the highest standard of product experience and technical aptitude is maintained within our dealer network.

Panasonic has continued to demonstrate its commitment to providing future-ready products, developing new hardware and software as network services and customer needs evolve. This is clearly seen in the Panasonic KX-TDA Hybrid IP-PBX systems which have been designed to provide advanced features and

support for Voice Over Internet Protocol (VoIP), first and third-party computer telephony and networking while maintaining their renowned ease of operation.

Panasonic KX-TDA Hybrid IP-PBX features also include backward compatibility, universal slots, CTI application interoperability via standard published interfaces, and remote maintenance and software upgrade capabilities.

\* Year ending 31st March 2008

Panasonic has continued to demonstrate its commitment to providing future-ready products, developing new hardware and software as network services and customer needs evolve.

## PANASONIC HYBRID IP-PBX SYSTEMS

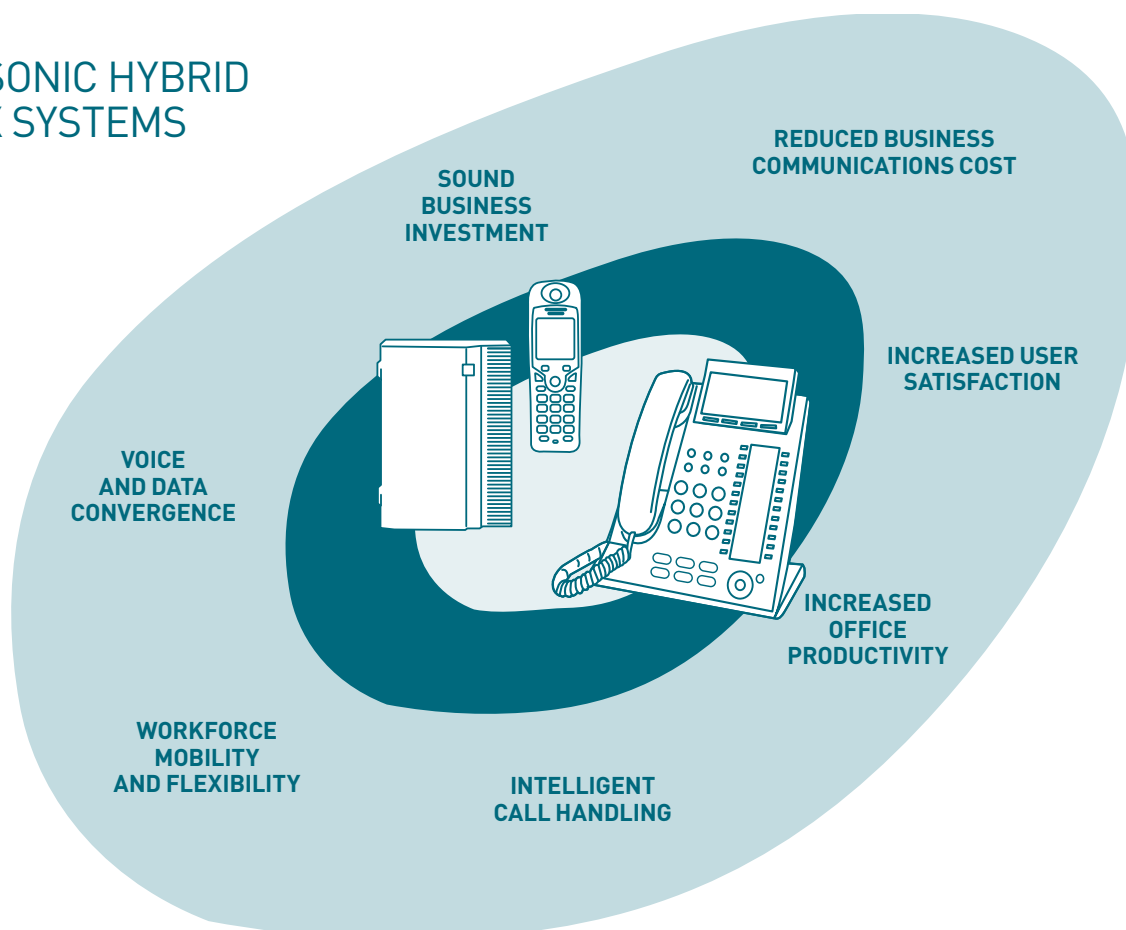

Investment in a telecommunication system requires business communication foresight. Businesses need to be able to effectively communicate today - yet want to make sure that they are properly equipped to handle the growing demands of their future communication needs.

The Panasonic KX-TDA Hybrid IP-PBX systems combine the advantages of traditional telecommunications with the convergence of IP technology offering maximum feature and functional flexibility to handle all your business communication needs - Today and in the Future.

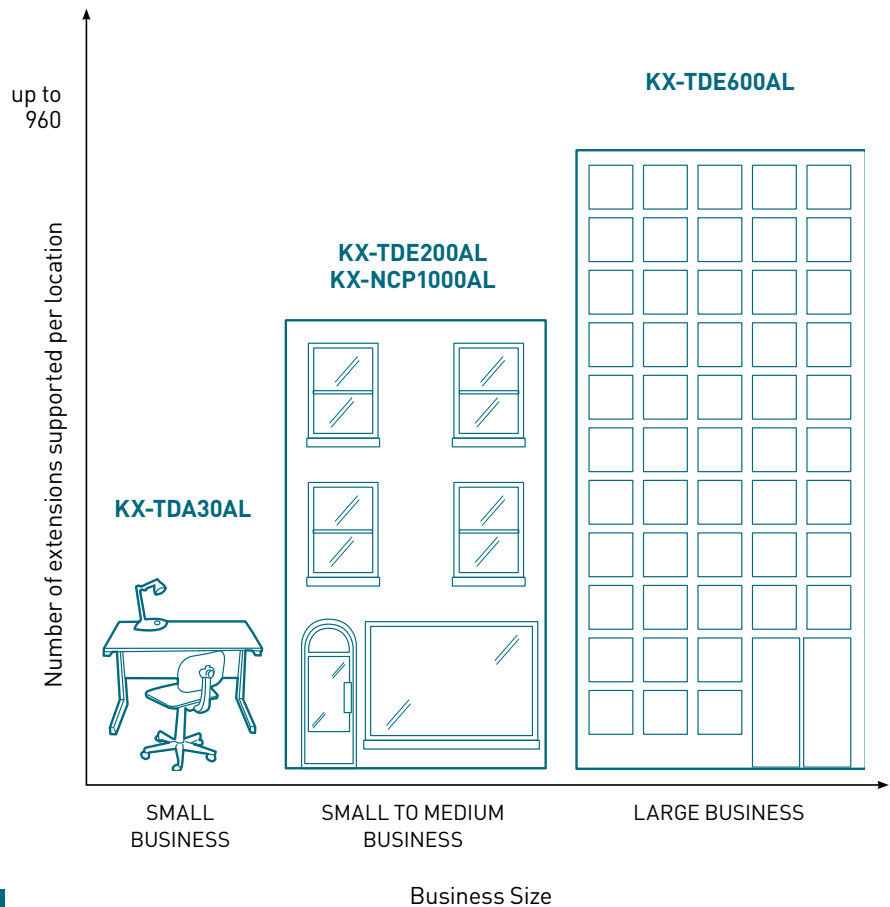

## Panasonic KX-TDA Hybrid IP-PBX the voice of business

### Reliability

Panasonic business telephone systems are manufactured to the highest possible standards at a factory that has earned ISO 9001 certification for design, development and manufacture of telecommunications equipment.

This is further supported by the provision of a factory warranty.

### Ease of Maintenance

In addition to renowned reliability, the Panasonic KX-TDA Hybrid IP-PBX system is also designed for quick, easy maintenance to keep system downtime to an absolute minimum.

### The Panasonic KX-TDA Hybrid IP-PBX is truly a business telephone system for today and tomorrow.

The system is a communications tool that can grow with your business. Due to the modular architecture, the system can be cost effectively expanded and upgraded to offer more services as your needs evolve. You can also upgrade your system to support new technologies such as VoIP while continuing to use your existing analogue or digital handsets.

### Scalability to Match Your Business Growth

Your new telephone system can grow with you with handsets and accessories that are common across the system range.



# REDUCED BUSINESS COMMUNICATIONS COST

## System Overview

The Panasonic KX-TDA Hybrid IP-PBX combines PBX features and reliability with IP technology to create a host of advanced functions.

Features such as Voicemail, Intelligent Call Handling for Call Centre application, Wireless DECT mobility, Computer Telephony Integration (CTI), Networking and Hospitality features are supported as well as optional VoIP gateway and PC Phone application.

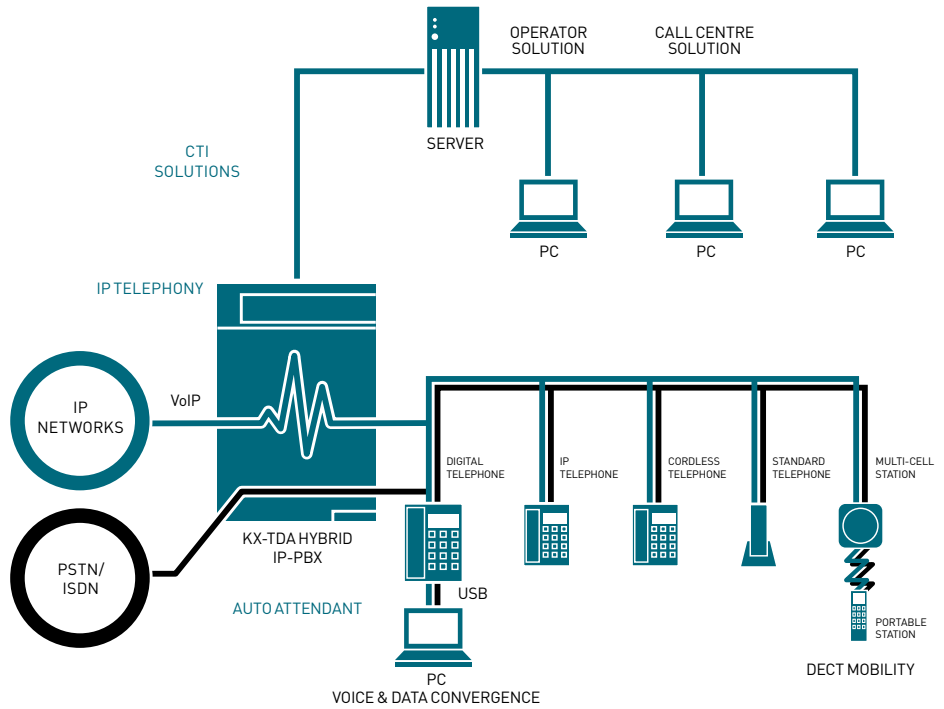

## eXtra Device Port (XDP) and Digital XDP (DXDP)

Use the XDP to add an analogue phone, cordless phone or other single-line device to your system, without the cost of an additional line. This lets you send a fax while talking to a customer. Or by connecting a modem to the XDP, you can download data from your PC or access the internet while talking. The DXDP allows you to increase the number of digital telephones without the cost of additional hardware. It lets you put functional digital phones in the hands of more of your staff to boost overall office productivity.

With Panasonic XDP feature, the system can be programmed to ring the fixed PBX extension and the wireless handset or mobile telephone simultaneously when receiving an incoming call. Three XDP parallel connections are supported.

## Keeping Telephone Costs Down

Any business could benefit from a low cost, easy to use and reliable inter-office networking system. Using a VoIP gateway, the system converts telephone voice signals into IP packets, making it possible for you to use VoIP technology even with existing telephone units. The Panasonic KX-TDA Hybrid IP-PBX also supports the QSIG\* protocol, making it effective for building a company-wide voice network. Automatic Route Selection (ARS) saves money by choosing the most inexpensive calling route. Also, in addition to cutting costs, VoIP technology and networking give you easier access within networks.

\*QSIG is an industry standard digital networking protocol.

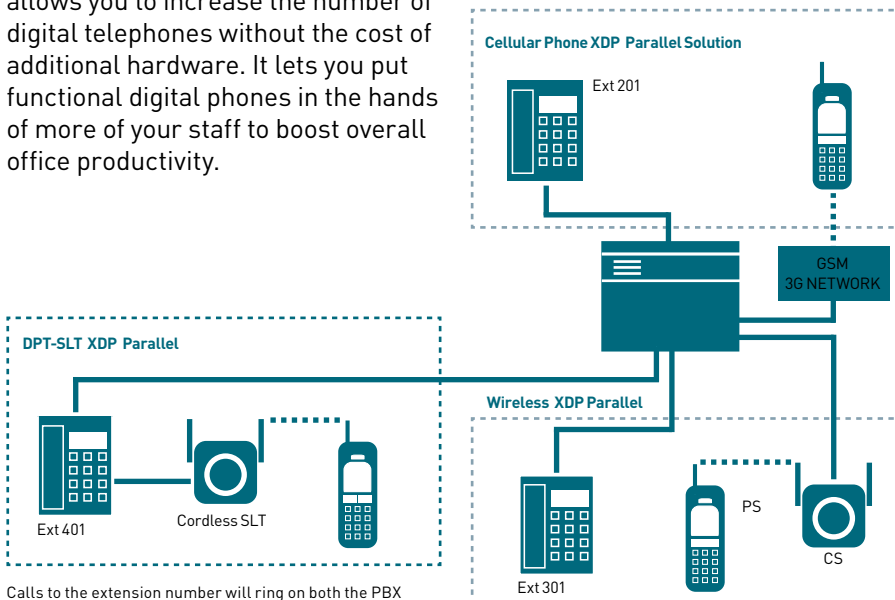

Calls to the extension number will ring on both the PBX extension and wireless DECT handset or mobile telephone.



## PHONE ASSISTANT

### Higher Productivity, Greater Customer Satisfaction via Desktop PC Integration

Panasonic Phone Assistant is a suite of desktop productivity applications that integrates with the KX-TDA Hybrid IP-PBX to provide a variety of collaboration tools to simplify and enhance real time communications for business telephone users.

Highly intuitive Phone Assistant Graphical User Interface (GUI) allows users to simply use a mouse to more effectively utilise the telephony features and manage calls with a simple point-and-click.

Panasonic Phone Assistant application empowers you with business tools to provide superior customer service.

There are 3 variations of Panasonic Phone Assistant that are targeted at different users. Phone Assistant users are able to do more in less time, increasing productivity.



### Incoming Call Popup

Phone Assistant unobtrusively informs you of incoming calls via a small pop-up window.

### Click To Dial Contacts

To call someone, click the Contacts tab to visually check to see if they are available and simply click to dial.

### Click Access to Phone Directory

KX-TDA Hybrid IP-PBX contact directory integration allows users

to create business or private contacts that show the presence and availability of all co-workers or can simply dial external business contacts by double clicking.

### Presence and Availability

The "Presence and Availability" function is fully incorporated into the application allowing you to see other contacts' phone status (e.g. Idle, Busy, Ringing, etc.). This feature helps to determine who is available to handle calls before you decide to call or transfer a call to them, greatly reducing the number of missed calls and lost communications.

### Instant Messaging

Instant messaging allows text messages to be sent to another Phone Assistant user's computer screen.

### Never Miss an Important Call

The software informs you of the number of calls and chat invitations while away from your desk, enabling you to return their call even if they did not leave a message.

### Record Conversation with Ease

PA Users can easily record conversations to Voice Mail at the press of a button. Conversation recordings can be listened to by accessing voicemail.

KX-TVM50/200 required.

### IP Softphone Option

An optional Softphone plug-in module allows remote users, call centres and other roaming employees to connect and access the corporate telephony applications over an IP network even in a remote location.

### IP Camera Integration

Panasonic IP Cameras can also be integrated, allowing users to answer a doorphone and open the door after viewing the IP camera video feed on screen.

## PHONE ASSISTANT STATUS

Phone Assistant Status application allows supervisors and team leaders an easy way to keep an eye on all their team members' telephony communication activities. Each supervisor can manage up to 128 extensions – monitoring phone status, call details, presence and availability – perfect for managing a team or an entire organisation.

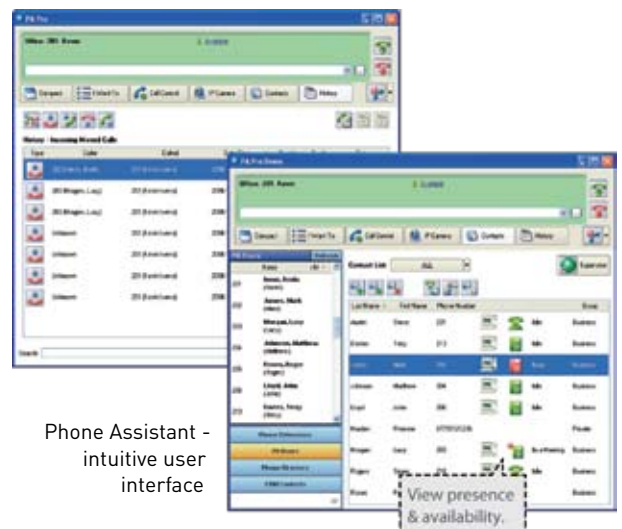

Phone Assistant - intuitive user interface

Features supported include:

- Drag and drop extensions to monitor
- Click to access call details
- Call monitoring

## PHONE ASSISTANT MANAGER

Phone Assistant Manager is an intuitive web browser-based application designed to make it easy for IT Administrators to administer Phone Assistant users and make typical Adds/Moves and configuration changes to their KX-TDA Hybrid IP-PBX right from their networked PC.

# KX-DT300AL DIGITAL PROPRIETARY TELEPHONES

Panasonic KX-DT300AL Series advanced desktop phones are designed for business users who require a range of feature-rich telephony devices to match their constantly changing business needs. They provide a wide range of features to support the right solution for all your business applications including contact centre agents, hotel rooms and advanced desktop applications with support for Bluetooth headsets.



Optional Bluetooth Module



Programmable Keys



Back-lit LCD Display



Easy To Navigate



Multi-tilt Angle Adjustment



## Advanced Digital Proprietary Terminals

These telephones offer superb voice quality thanks to handsfree speakerphone and integrated headset port.

The sleek, ultra-modern design, available in both black and white colour options, works well with any office decor.

Ergonomically designed with features and functions to enhance users daily productivity, they are ideal for many applications including contact centre agents, hotel rooms, to advanced desktop applications supporting a range of wired and Bluetooth headsets.

## Simple Integration

This advanced range integrates with Panasonic KX-TDA and KX-TDE as well as integration with the advanced KX-NCP Network Communication Platforms - allowing quick access to the entire spectrum of phone system features and applications.

## Main Features

Hands-free Communication with a Bluetooth Headset

- High-visibility white backlight
- Double-Tilt Design
- Large Alphanumeric Displays
- Easy Navigation Key
- Programmable Keys





\*<sup>1</sup> Optional: KX-DT346AL only

\*<sup>2</sup> Optional: KX-DT346AL only

Image: Model KX-DT346AL. Other models may vary.

## DIGITAL OR IP TELEPHONE TERMINALS



**KX-DT346AL**

- 6-Line Backlit LCD Display
- 24 Programmable CO Keys
- Digital Speakerphone
- Bluetooth® Module (Option : KX-NT307X)
- Add-On 12-Key Module (Option : KX-NT303X)
- 60-DSS Console (Option : KX-NT390AL)
- USB Module (Option : KX-DT301X)



**KX-DT333AL**

- 3-Line LCD Display
- 24 Programmable CO Keys
- Digital Speakerphone
- 60-DSS Console (Option : KX-DT390AL)



**KX-T7667AL**

- 1-Line LCD Display
- 12 Programmable CO Keys
- Digital Speakerphone
- 60-DSS Console (Option : KX-DT390AL)



**KX-DT390AL**

- 60 DSS Console



**KX-NT303X**

- Add-On 12-Key Module (Option : KX-DT346AL only)



**KX-NT300X**

- Panasonic KX-NT300X Series IP Telephone Terminals Support (Except KX-NT366X)

# WORKFORCE MOBILITY AND FLEXIBILITY



KX-TCA355AL  
Tough Type Model

Enjoy superb mobility no matter where you work, whether it is in an office, factory, warehouse, supermarket or other large facility. Panasonic Wireless DECT connectivity and Mobile Phone integration are here to help. The Panasonic KX-TDA Hybrid IP-PBX system lets you simply continue your current conversation over a lightweight, business-smart wireless telephone while you are away from your desk or moving around the office or across sites that are connected to a network of KX-TDA Hybrid IP-PBXs. Because the system is digital, the speech comes through loud and clear.



KX-TCA256AL  
Compact Business Model

The Multi-Cell DECT System is an integrated wireless system that is specifically designed for use with a Panasonic KX-TDA Hybrid IP-PBX.

### DECT Mobility

The system allows wireless communication over an extended range by using multiple cell stations that boost the flexibility and mobility of your wireless handset. Using the Wireless XDP, you can set your wireless telephone to have the same extensions as your desk phone and then receive calls even when away from the desk. You are always there, ready to receive your customers' calls and make the



KX-TCA155AL  
Basic Model

most of every business opportunity that comes along. This system provides automatic hand-over between cells, giving you true communication mobility even in large premises.

The KX-TCA256AL DECT handset combines small size and light weight with a host of powerful features. The KX-TCA155AL is a good choice for users who want good basic performance at a lower cost. And for users who require a ruggedised handset, the new Panasonic KX-TCA355AL meets strict dust and splash resistant IP54 standards.

\* The KX-TCA155AL, KX-TCA256AL and KX-TCA355AL must be connected to a Panasonic KX-TDA Hybrid IP-PBX System.

## KX-TCA155AL, KX-TCA256AL and KX-TCA355AL

### FEATURES

- 6-line, Blue LCD Backlight
- Illuminated Keypad
- Multiple Language Display
- Speakerphone
- Programmable Soft Keys
- PBX Functionality Support
- 200 Entry Phonebook
- Headset Compatible
- 9 Polyphonic Ringer Melodies and 6 Ringing Patterns
- Vibrate Alert\*
- Meeting Mode\*

\* KX-TCA256AL and KX-TCA355AL Only

## PANASONIC MULTI-CELL DECT SYSTEM FEATURES

### Easy Operation

- Graphical Icon Menu
- Dynamic Operation Guidance with Soft Keys

### Easy Access to PBX Features

Flexible Programmable Keys let you register PBX features and handset functions for quick, convenient access. A graphical PBX Feature Menu is also available to further improve operating ease.

### Blue LCD Backlight

Whenever you get a call or touch a key, the LCD lights up in blue so you can see who's calling and easily operate the phone - even in the dark.

### Seamless Connection – Automatic Hand-Over

There is no change in the connection quality as you move from one cell station area to the next while conversing with a colleague in the same building or with a customer outside.

### 200-Station Phonebook

The built-in telephone directory lets you store 200 station names and numbers.

### Automatic Answer / Optional Headset for Hands-Free Conversation

Plug in an optional headset and enjoy the ease and unrestricted freedom of hands-free communication.

With an optional headset, you can answer incoming calls without even touching the handset.

### Hot-Desking for Roaming Employees

Hot-Desking, enabled via 'Walking Extension' feature on Panasonic KX-TDA Hybrid IP-PBX, empowers your staff who work from different locations or departments within your office to move between different desks themselves – reducing the cost of moves, adds and changes.

Users can move desks or offices and be reached on their same number as well as transfer their own profiles and access to such features as access to voicemail, speed dials and pre-programmed functions by logging in to any unused desk phone with a pre-programmed ID number. Hot-Desking is a simple and effective solution that keeps all your staff in touch and in control of their communications.

### Greater Flexibility with Mobile Phone Integration

Panasonic KX-TDA Hybrid IP-PBX system allows for seamless integration of the office PBX network and mobile telephones. The system can be programmed to ring the fixed PBX extension and the mobile telephone simultaneously when receiving an incoming call. Calls to the mobile telephone can then be transferred back to another PBX extension if necessary.

With Panasonic KX-TDA Hybrid IP-PBX system and mobile phone integration feature, your staff can stay connected on the same phone number they use in the office while away from their desk, increasing staff productivity and customer satisfaction. Your key customers never have to be kept waiting again.

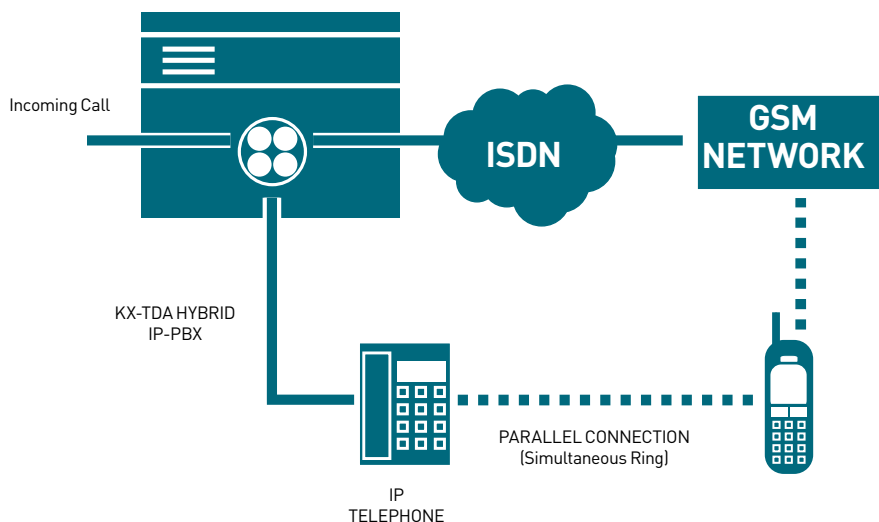

# INTELLIGENT CALL HANDLING

With its intelligent call-handling functions, the Panasonic KX-TDA Hybrid IP-PBX can serve as the core of an efficient contact centre that provides outstanding customer service. Use the system to automatically distribute incoming calls as desired. You can also program the system to direct callers to the appropriate group for efficient call handling.

## Call Centre Efficiency You Can Appreciate

Advanced call centre functions improve communication efficiency and allow you to serve customers more effectively. The system makes it easy to distribute calls, manage your telephone agents and control office use of the telephone system. Compatible with the CTI standard protocols, TAPI and CSTA, the Panasonic KX-TDA Hybrid IP-PBX can serve as the core of a powerful, high value added CTI.

## Superior Call-Handling Efficiency

You can assign a backup extension as an overflow destination for calls not answered within a specified period of time. You may designate any extension you want as the overflow destination—a company message box, for example—and you can designate different overflow

destinations for when the PBX is in day, lunch, break or night mode.

Designated member extensions can “log in” to join their group and begin handling calls, or “log out” to exit the group temporarily, such as when taking a break. An extension can also be allocated for use by the supervisor, who can access information about incoming calls to each group (the number of queued calls, the longest queuing time, etc.), change the log-in/log-out status and monitor the status of group members.

Other features, listed below, help ensure greater customer satisfaction and prevent missed business opportunities.

- VIP Call, which provides special handling for key customers
- Automated Attendant, which answers calls automatically
- Queuing, which puts the caller on hold and plays messages and music when no one is available.

The Panasonic KX-TDA Hybrid IP-PBX provides a variety of call distribution patterns. Effective use of the different patterns – Automatic Call Distribution (ACD), Uniform Call Distribution (UCD), Priority Hunting and Simultaneous Ring – can help you manage calls more efficiently.

## Virtual 24 Hour Receptionist Automated Attendant

Using the Message Card, you can easily set up an auto attendant to professionally handle all incoming customer calls to your business. An Auto Attendant can drastically reduce the amount of call traffic handled by the operator – allowing the operator to spend more time with your new or important customers.

The Auto Attendant can also answer multiple calls simultaneously, providing different greetings for different departments.

## Advanced Messaging for Improved Customer Service

Using the advanced KX-TVM Messaging Solution – each extension can be assigned its own personal mailbox that can be contacted any time of day or night. If a caller leaves a Voice Message for a user, the extension user is notified by a message-waiting lamp available on proprietary telephones or can be additionally notified via an email with Voice Message attached sent to the user’s personal computer.

Incoming call information is also recorded with the message and is displayed on the telephone. This information includes the caller’s telephone number, time of call and length of call.

With the advanced KX-TVM messaging solution, an incoming message that arrives while someone is out of the office will generate a notice automatically to her or his GSM phone and users can check their messages at appropriate times. The advanced KX-TVM messaging solution also supports 2-Way recording. It lets you confirm the contents of the phone call later, so messages are accurately relayed, or record conversations in their entirety for use as examples of proper telephone communication by experienced staff when training new employees.



# INTELLIGENT CALL REPORTING

## INTELLIGENT CALL REPORTING WITH KX-NCV200 ACD REPORT SERVER



ACD Report Server is designed to bring advanced call centre functions to users of Panasonic KX-TDA Hybrid IP-PBX systems. This provides useful functions such as real-time monitoring and call centre performance reports, and agent log-in.

### REAL TIME MONITOR

#### ACD (Automatic Call Distribution) Monitoring

Clearly knowing actual operating performance is vital to optimising informal call centre management.

#### ACD Monitor



Counter shows each status



Example: Incoming Calls, Waiting Calls in Queue, Lost calls, Total Calls, Answered Calls, Logged-in Agents, etc...

The Panasonic ACD Report Server lets supervisors monitor parameters, such as the number of active calls, agent status, queue status and agent/group performance.

### REAL TIME ANALYSIS

The number of incoming/outgoing calls and accumulated call data that are monitored by the ACD Report Client can be viewed in graph form. The user can also customise the format and select the data for producing graphs. These performance graphs are capable of changing to reflect changes in the ongoing status.

The following performance graph shows: -

1. Status of the ICD Group
2. Status of each agent

### Performance Graphs



### BUILT-IN VOICE MAIL

KX-NCV200 also offers useful Voice Mail function, as it is built on the same platform as TVM200 - providing a cost effective call centre reporting-voicemail solution to small medium enterprises

### LOG REPORT

Panasonic's informal call centre solution also provides a reporting function for the detailed analysis needed to improve call centre performance. This function allows users to create reports on call information. The following reports are provided.

#### Trunk Call Report

Managers obtain call information on trunks accumulated over a given period.

#### System Report

A system report shows a summary of the whole system accumulated over a given time.

#### Group Report

A group report shows a summary of selected ICD groups. Supervisors can use it to obtain statistics for each group.

#### Agent Report

An agent report shows a summary of selected agents in the informal call centre. Supervisors can use it to obtain statistics for each agent and to allocate resources.

#### Agent ID based Report

An agent ID based report shows a summary of selected agents. Agents are selected by Agent ID. Supervisors can use the report to obtain statistics for each agent ID.

#### Agent Log Report



ACD Reports

# VOICE AND DATA CONVERGENCE

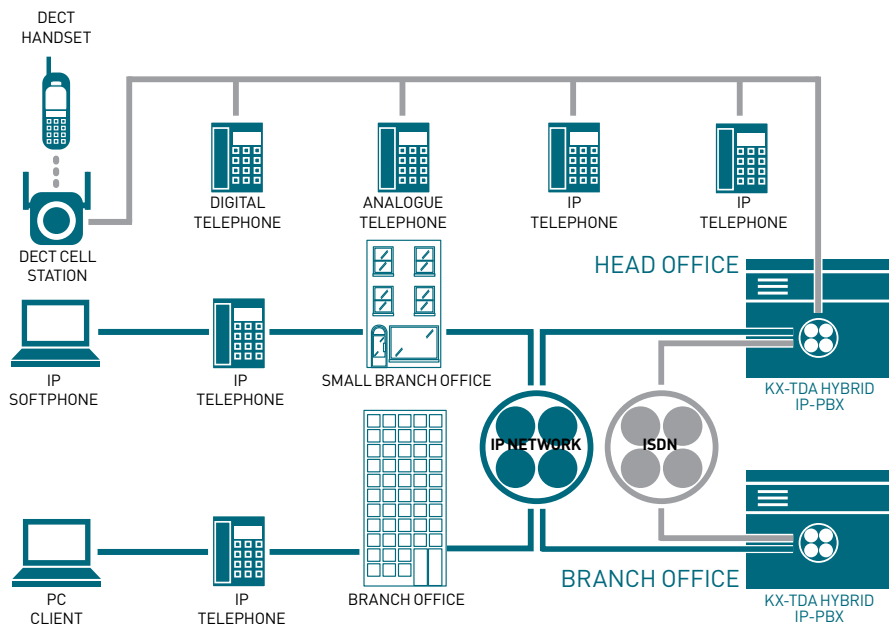

IP network infrastructure, which already exists in the majority of companies, can now carry voice along with data. Designed to support convergence through a modular structure, the system allows a harmonious migration towards VoIP, allowing voice and data communication to work within the same network.

## Voice Over IP (VoIP)

VoIP is the latest proven technology for voice communication where packets of digitally compressed voice are sent over IP data networks. These packets are converted back to voice once they reach the destination.

By utilising existing data networks, VoIP can bypass PSTN and therefore avoid all costs associated with PSTN calls no matter how far the distance and how long the conversation. In addition, VoIP also allows for more advanced telephony solutions and applications.

## VoIP Gateway Card

The VoIP Gateway Card makes it possible for you to use VoIP technology with your present telephone handsets and utilise your company's corporate data network without the need for separate, dedicated leased lines.

It is an ideal solution for site-to-site communication between multi-site offices and retail chains - as well as for networking branch offices allowing for a flexible working environment and lower costs.

## Hybrid IP-PBX and Desktop PC Integration

With the Phone Assistant software, you can also integrate your Panasonic KX-TDA Hybrid IP-PBX system with the database on your desktop PC, giving you a powerful Customer Relationship Management (CRM) support tool and improved call handling.

Selective or Automatic Call Recording, Intelligent TAM, as well

as Microsoft Outlook Synchronisation are just a few of the exceptional features that can provide enhanced added functionality to telephony power-users in your company.

## Advanced Networking

The Panasonic KX-TDA Hybrid IP-PBX system provides users with the ability to monitor the status of extensions connected to other systems in the network (maximum of 8) when they are networked together using ISDN or IP.

Up to a maximum of 250 extensions across the network can be monitored through the flexible buttons on the Panasonic telephones which are assigned as Network Direct Station Selection (NDSS) buttons. If the monitored extension is busy, the red lamp on the NDSS button will light up and if the extension is idle, the lamp will remain off.

The Panasonic KX-TDA Hybrid IP-PBX system also supports other networking features such as:

- Centralised Voice Mail which allows a network of systems to share the Voice Processing System (KX-TVM50/200AL) connected to a system in the network.
- Network Incoming Call Distribution (ICD) Group in which calls can be distributed to extensions that are grouped across 5 different locations.

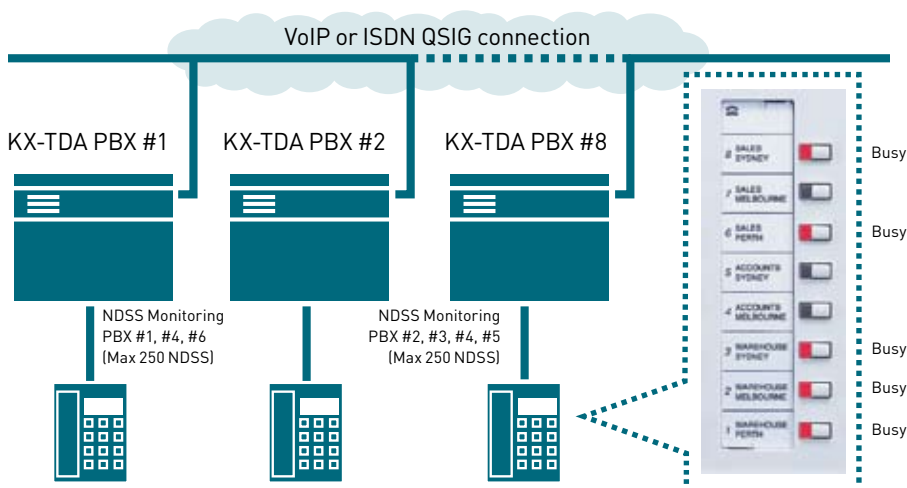

# VOICE AND DATA CONVERGENCE

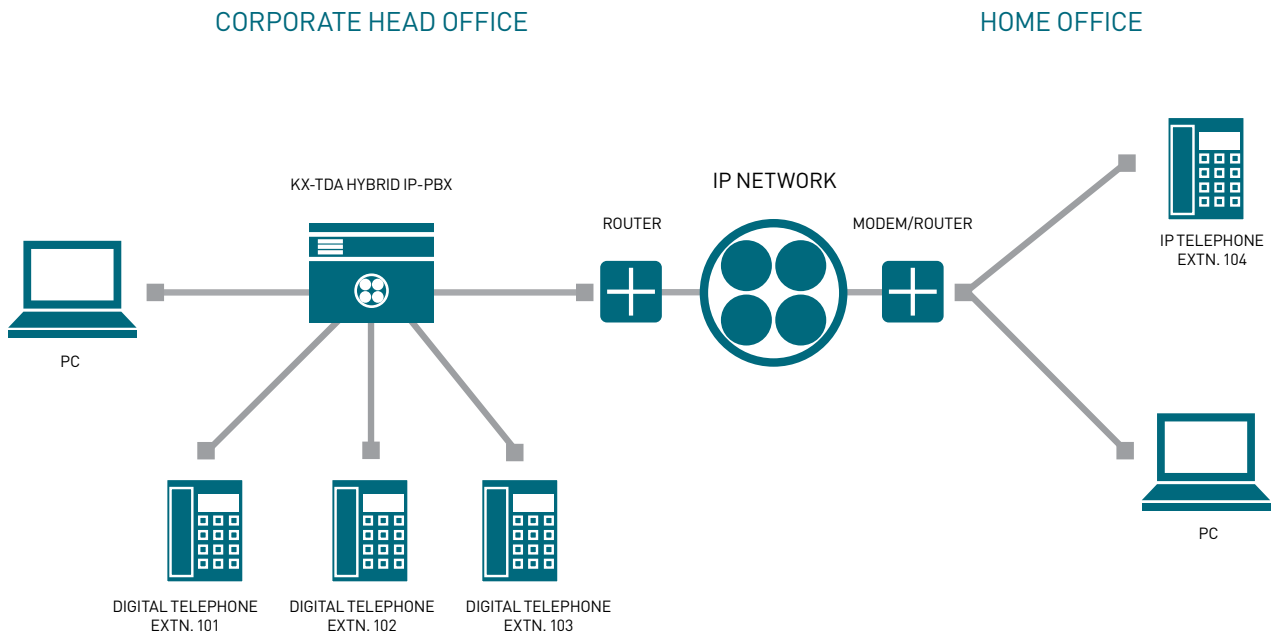

## IP Telephony

Customers interested in gradually evolving their businesses using IP telephony can benefit from the introduction of Panasonic IP telephones (KX-NT300 series) and IP Extension Card.

Based on the familiar Digital Proprietary Telephones, the KX-NT300 IP telephones include the familiar one touch feature access to:

- Call Hold
- Conference Call
- Call Transfer
- Call Forward and many more

Panasonic IP Telephony can extend the telephony network to remote/home office environment over a business grade data network.

Panasonic IP Telephony is the perfect solution for both home office or remote workers.

## IP SoftPhone Connectivity for Mobile Professionals

Panasonic's KX-NCS8102X IP SoftPhone provides mobile business professionals with access to the full functionality of the Panasonic Hybrid IP-PBX from any location with a laptop or PC and a broadband connection. With IP SoftPhone, your laptop becomes an extension of the Panasonic IP-PBX system enabling you to initiate or receive calls from home or wherever business takes you.

The IP SoftPhone also allows you to speed dial work colleagues from any location – saving time and money. Other features include: -

- Recording of conversations including conference calls onto your PC
- Dial Paste from Microsoft Outlook, Excel or other applications for quick and easy dialling
- IP Network Status indicator



# CUSTOMER SOLUTION FOR YOUR BUSINESS

For the majority of businesses, personal contact with the customer is a significant factor for success. The telephone system is at the heart of all communications – no matter how the communication is conveyed (via IP, by traditional telephony or by employing wireless technology).

What is crucial for businesses is quality and reliability. Panasonic provides a wide variety of solutions to cover any individual requirements.



## SYSTEM SPECIFICATIONS

### SYSTEM CAPACITY

Maximum Trunk Line Capacity		KX-TDA30AL	
Analogue CO / ISDN BRI		12	
VoIP (H.323)		4	
VoIP (SIP)		8	

Maximum Extension Capacity	Without Additional AC Adapter	With Additional AC Adapter
	Without MEC Card	With MEC Card
SLT		24
D-PT	24	48
A-PT		4
IP-PT		4
Total Extensions (max)	28	52

### MAXIMUM TERMINAL EQUIPMENT

Terminal Equipment Type	Without Additional AC Adapter	With Additional AC Adapter	
	Without MEC Card	Without MEC Card	With MEC Card
IP Extension	4	4	
SLT	24	24	
KX-T7600 series DPT/DSS console	Total 24	Total 24	Total 48
KX-DT300 series DPT	24	24	48
KX-DT300 series DSS console	4	4	
DSS Console	4	4	
Cell Station	4	8	
Wireless Telephone	28	28	
Voice Processing System	1 System*1	1 System*1	
SLT, PT, DSS console, and VPS	Total 28	Total 28	Total 52
Door Opener	4	4	
Doorphone	4	4	
External Sensor	4	4	
External Relay	4	4	
Add-on Key Module	Total 24	Total 24	48
USB Module	Total 24	Total 24	24

\*1 A maximum of 8 channels of a single VPS can be connected to the Hybrid IP- PBX.



Rear view of the KX-TDA30AL. KX-TDA30AL can be rack mounted.

## SPECIFICATIONS

Feature	Model	KX-DT346AL	KX-DT333AL	KX-T7667AL
LCD		24 digits x 6 lines Graphic	24 digits x 3 lines Character	16 digits x 1 line Character
LCD Backlight		Yes	-	-
Programmable CO Keys		24	24	12
LCD Contrast Control		4 levels	4 levels	3 levels
Handset/SP-phone Volume Control		H/S:4,SP:12	H/S:4,SP:12	H/S:4,SP:12
Ringer Volume Control		Electrical Vol.*3 (H-M-L-UL-OFF)	Electrical Vol.*3 (H-M-L-UL-OFF)	Electrical Vol. (H-M-L-UL-OFF)
Message/Ringer Lamp		Yes*2	Yes*2	Yes*1
OHCA		Yes	Yes	-
Whisper OHCA		Yes	Yes	Yes
XDP		Yes	Yes	-
D-XDP		Yes*4	Yes	-
Headset Jack (ø2.5mm)		Yes	Yes	Yes
Auto Redial		Yes	Yes	-
Off-Hook Monitor		Yes	Yes	Yes
Handset/Headset Mic Mute		Yes	Yes	Yes
Speaker Phone Mic Mute		Yes	Yes	Yes
Phone Directory		Yes	Yes	Yes
Feature Access		Yes	Yes	-
(Out-going) Call Log		Yes	Yes	Yes
(In-coming) Call Log		Yes	Yes	Yes
Melody Ringer		10 titles	10 titles	-
Colour		Black or White	Black or White	Black or White
Option Unit Connention				
KX-DT301X USB Module		Yes	-	-
KX-NT303X Add-on 12 Key Module		Yes	-	-
KX-NT307X Bluetooth® Module		Yes	-	-
KX-DT390AL 60 DSS Console		Yes	Yes	Yes

\*1 Single coloured LED

\*2 Dual-coloured LED (Green & Red)

\*3 20 ring types and 10 melodies are available.

\*4 D-XDP not available when KX-NT307X or KX-NT301X connected.

## FEATURE LIST

### System Features

- Automatic Call Distribution (ACD)
- Automatic Fax Transfer
- Automatic ISDN Setting (BRI)
- Automatic Route Selection (ARS) / Least Cost Routing (LCR)
- Background Music (BGM)
- Budget Management
- Busy on Busy
- Call Park with Indication
- Call Pickup Group
- Call distribution by Caller ID
- Class of Service (COS)
- CTI (CSTA, TAPI)
- Data Line Security
- Delayed Ringing
- Direct In Lines (DIL)
- Direct Inward Dialling (DID)
- Direct Inward System Access (DISA)
- Door-Phone / Door Opener
- Echo Cancellation
- Extension Lock
- External Sensor/Relay for Alarm Notification
- Emergency Call
- Existing APT / DPT Compatibility
- External BGM
- Flexible Numbering Plan (4-digits)
- Floating Extension
- Greeting Message
- Host PBX Access Code
- Hunting Group
- Hurry-Up Transfer
- Incoming Group (Hunting Group)
- Intercept Routing - Busy / DND
- Intercept Routing - No Answer
- Intercept to Trunk
- Line Monitor (CO)
- Main Processing (MPR), Card / CS software download
- Manager Functions
- Mobile Phone Integration
- Multiple Language Support
- Online Diagnostics
- Operator Functions
- PC Console / PC Phone
- PC Programming
- Paging Group
- Quick Setup
- Remote Alarm Notification
- Remote Extension Status Control through DISA
- Remote Extension Lock
- Ring Group

- Simplified Voice Message (SVM)
- Special Carrier Access
- Station Message Detail Recording (SMDR)
- SMDR 24 Hour and 12 Hour Time Format
- SMDR Caller ID Printing
- System Memory Expansion
- Tenant Service
- Timed Reminder
- Time Service (Day / Night / Lunch / Break)
- Toll Restriction
- Trunk Group
- Uniform Call Distribution (UCD)
- User Group
- VIP-Call
- Visual Caller ID

### Voice Mail (VM) Features

- Automatic Configuration - Quick Setup
- Call Forwarding to VM
- Caller's Identification Notification to VM
- Email Integration\*1
- Intercept Routing to VM
- Telephone Display, Menu driven VM operation
- Live Call Screening (LCS)
- Remote PBX Data Control by VM
- VM Data Control by PBX
- VM (Digital / DTMF) Integration
- VM Group
- VM Mail Transfer
- VM Menu on the LCD\*1 (KX-T7636 only)

### Extension Features

- Absent Message
- Account Code Entry (Forced)
- Automatic Redial
- Boss - Secretary
- Broadcasting
- Caller ID to Single Line Telephone
- Call Forwarding (All Calls, Busy, Busy / No Answer, No Answer, Follow Me, From Incoming Group)
- Call Hold
- Call Pickup (Directed, Group, DSS, Deny)
- Call Transfer (Screened, Unscreened, One-Touch Transfer, Transfer Recall)
- Conference (3-Party Conference, Multi Party Conference, Unattended Conference)
- Dial Type Selection
- Digital Duplex SP-phone
- Digital eXtra Device Port (DXDP) \*2 (ZDPTs in One Extension Port)
- Direct One-Touch Answering

- Do Not Disturb (DND)
- DSS Console
- Executive Busy Override
- Extension Directory
- Extension-to-Trunk Call Duration Time
- External Feature Access
- Flexible Buttons
- Hands-free Operation
- Handset / Headset Selection
- Large Telephone Display Features with Back-lit
- LED control for CTI
- Log-In / Log-Out
- Message Waiting
- Multi-Lingual Display
- Multiple Hop Call Forwarding (4 steps)
- Music on Hold
- Off-Hook Call Announcement (OHCA)\*2
- Off-Hook Monitor
- One-Touch Dialling
- Paging (Deny, Paging Transfer)
- Paralleled Telephone (APT / DPT+SLT, DPT / SLT+PS)
- Redial, Last Number
- Remote Station Control
- Special Carrier Access
- Speed Dialling - Personal / System
- Time and Date Display
- Tone-Pulse Conversion
- Trunk Answer from Any Station (TAFAS)
- Walking Class Of Service (COS)
- Whisper OHCA (Off-Hook Call Announcement)
- Wrap-Up
- eXtra Device Port (XDP)

### DECT Features

- Automatic Handover
- DECT CS on Digital Extension Port
- Headset Compatibility
- Incoming and Outgoing Call Log
- Telephone Display control via CTI\*3
- Wireless XDP Parallel Mode
- Vibrator Ring (KX-TCA256AL and KX-TCA355AL only)

### ISDN Service Features

- Advice Of Charge (AOC)
- Call Hold (HOLD)
- Calling Line Identification Restriction (CLIR)
- Calling Line Identification Presentation (CLIP)

- Completion of Calls to Busy Subscriber (CCBS)
- Connected Line Identification Presentation (COLP)
- Connected Line Identification Restriction (COLR)
- Direct Dialling Inward (DDI)
- ISDN 3 Party Conference (3PTY)
- ISDN Call Forward (CFU / CFNR / CFB)
- ISDN Call Transfer (CT)
- ISDN Extension
- Malicious Call Identification (MCID)
- Multiple Subscriber Numbers (MSN)

### Networking Features

- Alternate Routing
- ARS with VoIP
- Call Log (Public Call through Private Network)
- Caller ID to SLT (Public Call through Private Network)
- Centralised Voicemail
- DISA Call to the Network
- Network Busy Lamp Field (BLF)\*3
- Network Closed Numbering
- Network Direct Station Selection (NDSS)
- Network ICD Group
- Private Network to Public Network
- Public Network to Private Network
- QSIG Connection
- Speed Dial Name (Public Call through Private Network)
- Tandem Connection
- Tie Line
- Transfer to Network PBX
- Virtual Private Network (VPN)
- VoIP Network

### Built-in Hotel Features

- Call Billing for Guest Room
- Remote Wake-Up Call
- Room Status Control
- SMDR for External Hotel Application

DPT: Digital Proprietary Telephone  
APT: Analogue Proprietary Telephone  
SLT: Single Line Telephone  
PS: Portable Station

\*1 When the KX-TDA Hybrid IP-PBX is integrated with a KX-TVM50 or KX-TVM200 Voice Processing System. \*2 This feature is unavailable with the KX-NT300.

\*3 Optional software required.

\* Note: All these features in this feature list are supported on MPR Version 5.x.



**KX-TDA300AL**  
IP-PBX SYSTEM

the voice of business

**Panasonic**  
Ideas for life



**KX-NCP1000AL**  
UNIFIED COMMUNICATIONS SYSTEM

the voice of business

**Panasonic**  
Ideas for life



**KX-TDE200/600AL**  
PURE IP-PBX SYSTEM

the voice of business

**Panasonic**  
Ideas for life



**MULTI CELL DECT SYSTEM**

the voice of business

**Panasonic**  
Ideas for life



**VOICE PROCESSING SYSTEM**  
KX-TVM550AL  
KX-TVM200AL

the voice of business

**Panasonic**  
Ideas for life

**Head Office NSW**

Austlink Corporate Park  
1 Garigal Road  
BELROSE 2085  
PH: (02) 9986-7400  
FAX: (02) 9986-7450



For further information or the location of your nearest Panasonic Authorised Dealer, please telephone **Panasonic Customer Care Centre** on **132 600**